

# Eddy Current Position Sensor for Diverse Safety Rod Drive Mechanism of Prototype Fast Breeder Reactor

## EXECUTIVE SUMMARY

Diverse Safety Rod Drive Mechanism (DSRDM) is an important safety mechanism of PFBR. During reactor operation the Diverse Safety Rod (DSR) is held in position above the reactor core, by an electromagnet. On receiving the SCRAM signal, the electromagnet de-energizes, thus releasing the DSR, which drops under gravity. It is decelerated by the sodium dash pot after traveling free-fall distance and rests at bottom most position. It is mandatory to check whether the DSR has reached the bottom most deposited position and also to measure the free fall time. An Eddy Current based Position Sensor (ECPS) is designed. The sensor is tested in sodium environment using a model.

## OUTLINE

In PFBR, there are three Diverse Safety Rod Drive Mechanisms (DSRDM) in the control plug, which hold the diverse safety rods (DSR). During normal operation, DSRs are held outside the active core region by an electromagnet. On receiving SCRAM signal, the electromagnet de-energizes and drops the DSR, which falls under gravity in sodium. DSR gets decelerated due to damping action of sodium in the dash-pot after traveling a certain free-fall distance. It is mandatory to check whether the DSR has reached the bottom most deposited position and also to measure the free fall time. An eddy current based position sensor (ECPS) compatible with the liquid sodium environment has been designed for incorporation in DSRDM to meet this requirement.

A critical constraint in this important requirement is that it is not possible for the sensor to have any electrical connectivity with the in-core components. To circumvent this problem an indirect excitation through inductive coupling is incorporated in the design of the sensor. Also an innovative pick-up coil has been incorporated to isolate the extremely weak signals of the sensor and detect them with efficiency.

Schematic diagram of the sensor coil arrangement is shown in Figure 1. The primary and pick-up coils are located in the mobile assembly of DSRDM and secondary, signal transfer and sensor coil, which are connected serially are located on the stationary DSR sheath side. The secondary coil is placed concentric to the primary and similarly signal transfer coil is placed concentric to the pick-up coil. The induced voltage in secondary would drive a circulating current in all the three coils on secondary side. The magnitude and phase of this current depends on the total impedance of coils on secondary side. When the DSR is dropped, the sodium in the DSR subassembly is displaced by DSR. The impedance of sensor coil changes with the DSR is in the deposited condition as compared to non-deposited condition. Accordingly, flux linkage with pick-up coil varies, thereby changing the voltage induced in it. This indicates presence of DSR near sensor coil.

Space constraint is a challenge for accommodating ECPS in DSRDM. A mechanically compliant design has been adopted. The design (Fig.2) was arrived after going through a number of rigorous design iterations. A detailed parametric study was done with respect to coil design, DSR material, and operating frequency using computer simulation to arrive at the balanced requirement of both the space constraints and high sensitivity.

The ECPS model (Fig.3) was fabricated for testing. All coils were made with MI cables for suitability to high temperature and sodium service. It was first tested successfully in air. Later the ECPS model was introduced in Test Vessel-2 of SILVERINA (Commissioned during SILVER Jubilee of IGCAR for sodium(Na) testing). The tests were conducted at various temperatures in sodium. Sensitivity of the order of 10% to 13% was achieved at 550 °C. This sensitivity is sufficient for detection of DSR.

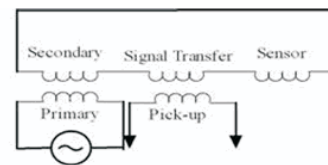

Fig 1: Schematic diagram of ECPS

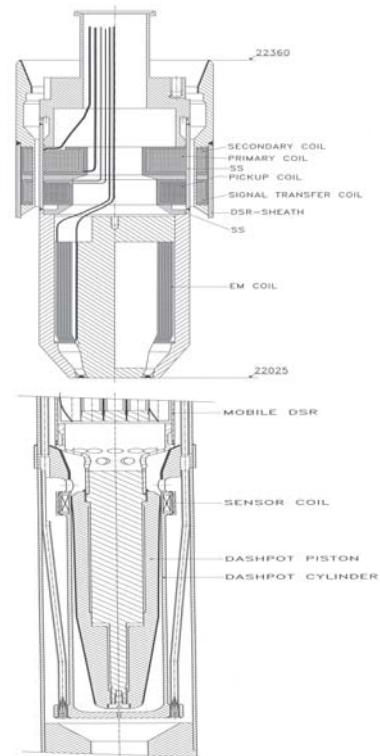

Fig 2 : Optimised design of ECPS



Fig. 3 : ECPS testing in sodium environment

## ■ ADDITIONAL INFORMATION

Eddy current based sensors are widely used as position sensors in many engineering applications and as proximity detectors in security applications. These operate on the principle of magnetic induction. However, these sensors as such cannot be adopted for our application due to the critical restriction that it is not possible for the sensor to have any electrical connectivity with the in-core components. The innovative indirect excitation adopted in this design overcomes this restriction. The eddy current position sensor operates by detecting the change in the sensor coil impedance, as a result of a target approaching the vicinity of the sensor. But due to the restriction in accessing the output from the sensor coil, an innovative pick-up coil is designed to measure the change in impedance.

## ■ GENERAL EXPLANATION RELATED TO THE DESCRIPTION

There are three Diverse Safety rod (DSR) in the core of the PFBR. During normal operation of the reactor, DSR is held outside the active core region by electromagnet, which is at the bottom end of Diverse Safety Rod Drive Mechanism (DSRDM). DSR moves inside a stationary hexagonal sheath. Both together are called as Diverse Safety Rod- Sub Assembly (DSR-SA). DSRDM is partially immersed and DSR-SA is fully immersed in hot sodium. Whenever there is a SCRAM signal, the electromagnet holding the DSR gets de-energised and the DSR falls under gravity. At the end of the free fall, it is decelerated by a sodium dash pot and is brought to rest. The specified free fall time of DSR plus the response time of the electromagnet should be within prescribed limits to ensure fast shutdown of the reactor. We need a position indication system to record the free fall time/total travel time of DSR whenever it is dropped into active core during SCRAM action. The free fall time is defined as the time elapsed between the instant at which the DSR is detached from the Electromagnet of DSRDM and the instant at which the dashpot action is initiated. The test set-up for sodium testing of ECPS is shown in Figure.4. The primary coil is excited, which generates induced voltage in the secondary side. The current in the sensor coil, which is located in the dashpot region, generates an oscillating magnetic field, which induces eddy current as the target (DSR with ferromagnetic piston) traverses near the sensor coil thus reducing the impedance of the coil. The restriction in accessing the output from sensor coil is overcome by the novel design of pair of signal transfer and pick-up coils. Hence the movement of the DSR, near the sensor coil is reflected as change in impedance in sensor coil, which is sensed via the pick-up coil.

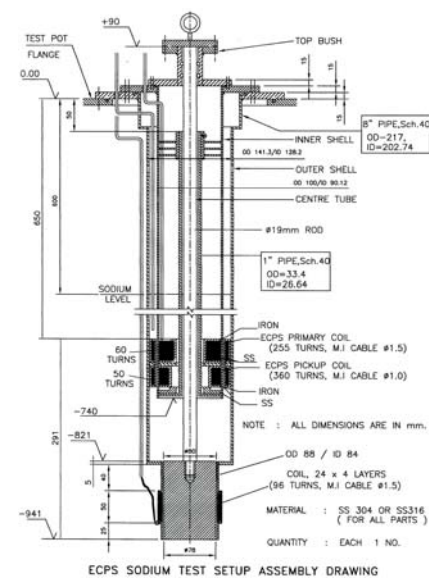

Fig. 4 : Test set-up for sodium testing of ECPS

## ■ BRIEF DESCRIPTION OF THEORETICAL BACKGROUND

According to the Faraday's law of Induction, the induced eddy current flows in an electrical metal conductor (target), if the conductor is located in a time changeable magnet field. The magnet field is generated here by an alternating current flowing in a coil. The eddy current generates an opposite magnet field, which superimposes with the exciting magnet field. As a consequence, the impedance of the sensor coil changes. Similarly the ECPS works on the principle of mutual inductance. As the ferromagnetic piston of the DSR approaches the sensor coil, the impedance of the coil changes, which in turn varies the impedance of all the three coils in the secondary side. The change in impedance in the sensor coil is sensed using mutual inductance through a pick-up coil. The change in impedance indicates the presence of DSR near the sensor coil.

## ■ ACHIEVEMENT

An indirect excitation has been incorporated in eddy current based position sensor for the first time. An innovative pick coil has been introduced, again for the first time, to isolate the extremely weak signals and detect them with efficiency. The design is optimised using computer simulations to meet the dual requirement of both the space constraints and high sensitivity.

## ■ PUBLICATIONS ARISING OUT OF THIS STUDY AND RELATED WORK

1. S. Sosamma, R. Vijayashree and C. Babu Rao, Report No. PFBR/31130/EX/1004/R-A, July, 2004.
2. S.K. Dash, S. Sosamma and G. Vijayakumar, Report No. IGC/FRTG/STG/ED&SS/99118/EX/3010/REV-A, Dec 2005.
3. Prashant Sharma, S.K. Dash, G. Vijayakumar and S. Sosamma, Report No. PFBR/31130/EX/1009/REV A, Feb 2007.

### Further inquiries:

Dr. C. Babu Rao, Non Destructive Evaluation Division  
Metallurgy and Materials Group, IGCAR, e-mail: cbr@igcar.gov.in